

CLARKE®

STRONG-ARM



TELESCOPIC BOTTLE JACK

MODEL NO: CTBJ5, 10 & 12

PART NO: 7621037, 7621050 & 7621795

OPERATION AND MAINTENANCE INSTRUCTIONS



GC0215

INTRODUCTION

Thank you for purchasing this CLARKE Bottle Jack.

Before attempting to use this product, please read this manual thoroughly and follow the instructions carefully. In doing so you will ensure the safety of yourself and that of others around you, and you can look forward to your purchase giving you long and satisfactory service.

Keep these instructions for future reference.

GUARANTEE

This product is guaranteed against faulty manufacture for a period of 12 months from the date of purchase. Please keep your receipt which will be required as proof of purchase.

This guarantee is invalid if the product is found to have been abused or tampered with in any way, or not used for the purpose for which it was intended.

Faulty goods should be returned to their place of purchase, no product can be returned to us without prior permission.

This guarantee does not effect your statutory rights.

SPECIFICATIONS

	CTBJ5	CTBJ10	CTBJ12
Rated Load	5 tonne	10 tonne	12 tonne
Min Height of saddle	220 mm	210 mm	235 mm
Max Height of saddle	495 mm	590 mm	580 mm
Pump oil capacity	475 ml	610 ml	850 ml
Dimensions (L x W x H) mm	130x135x220	175x165x210	190x180x235
Weight	7.8 kg	11.1 kg	15.15 kg
Length of Operating handle	590 mm	590 mm	590 mm

SAFETY PRECAUTIONS

1. Do not exceed the rated capacity of the jack.
2. Do not allow personnel to operate the jack unless they have read these safety precautions.
3. Do not operate the jack if damaged.
4. Use the jack in a suitable, well lit work area.
5. Keep the work area clean and tidy and free from unrelated items.
6. Only use the jack on level and solid ground, preferably concrete. Avoid soft/unmade ground as the jack may sink in.
7. Ensure non-essential persons keep a safe distance whilst the jack is in use.
8. Ensure there are no personnel or obstructions under the vehicle before lowering.
9. Do not work under the vehicle until it is fully supported by axle stands.
10. Keep hands etc clear of the vehicle until lifting is complete.
11. Ensure that you can see the saddle and jacking point throughout the jacking operation in case there is any relative movement.
12. Always ensure that the jack saddle is centred and stable on the lifting point before lifting and position the jack to avoid operating it from under the vehicle.
13. Check the vehicle weight and recommended lifting points by referring to the vehicle owners manual. Ensure the lifting point is not corroded.
14. Never tamper with the jack or modify it in any way, as this could prove to be dangerous and will invalidate the guarantee. Only use the jack for the purpose for which it is intended.
15. Use appropriate safety equipment, such as protective footwear, when using this jack.
16. Ensure that the jack is properly maintained and lubricated at all times, and that no corrosion is allowed to weaken any part of it.
17. If the jack has been subjected to an abnormal load or shock, it should be removed from service immediately and fully inspected by qualified personnel, and passed as serviceable, before being used again.
18. When not in use, store the jack, fully lowered, in a safe, dry, childproof area.
19. Always inspect the jack before use. Ensure that all parts are in good condition and operating smoothly, and that no cracks or distortion is apparent. If in doubt do not use.

20. Never push a vehicle off the jack or start the engine while supported only by the jack.
21. Do not use if an oil leak is apparent. Consult the Clarke Service Department.
22. If more than one jack is used in unison, they must all be of the same rating and be raised at the same speed to reduce the possibility of the load slipping.

SAFETY SYMBOLS

The following safety symbols may be found on the product.



Read the user manual before use.

LIFTING OPERATIONS AND LIFTING EQUIPMENT REGULATIONS 1998

This jack, depending on use, may fall within the scope of LOLER. It is the owner's responsibility to determine whether or not it does and, if so, to comply with any applicable requirements in LOLER, for having the jack thoroughly examined.

ENVIRONMENTAL PROTECTION

1. Take care to ensure that if hydraulic oil is spilt that it is cleaned away using sand or treated with absorbent granules designed for the purpose.
2. Always make every effort to contain any spillage and prevent ingress into the local water course.

PRODUCT FEATURES

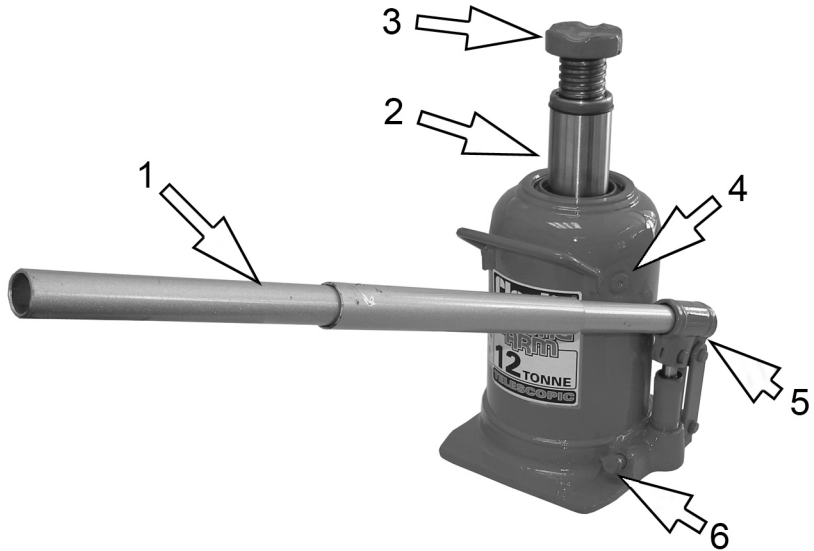

(CTBJ12 shown)

1	3 x Handle Tubes
2	Ram
3	Screw Extension
4	Oil Filler Plug
5	Actuating Lever
6	Release Valve

UNPACKING

During transit or storage, it is possible that an air pocket may have developed within the hydraulic ram, and the ram action may therefore appear to be 'spongy'. In this case the jack may require purging as described on page 7.

If the column does not reach its full height, the ram oil level may require topping up, as described in the Maintenance section.

OPERATION



WARNING: ENSURE THE SAFETY PRECAUTIONS ARE STRICTLY FOLLOWED. NO RESPONSIBILITY CAN BE ACCEPTED FOR INCORRECT USE OF THE JACK

RAISING A VEHICLE

1. Ensure the vehicle is stable and is on firm level ground with the wheels chocked before positioning the jack so that is directly beneath the lifting point. DO NOT rely upon the vehicle handbrake alone to prevent vehicle movement.
2. Ensure the jack is on solid ground. If not, place a suitable piece of solid wood of sufficient size to provide adequate support beneath the jack.
3. Consult the vehicle owners manual to ascertain the location of suitable jacking points and position the jack beneath the designated lifting point.
4. Locate the slotted end of the jack handle on to the release valve and turn fully clockwise to close the valve.
5. Set the screw extension (CTB10 & 12 models) in contact with the lifting point. Pump the handle and raise the ram so that the jack and lifting point are in full contact. Before proceeding further, make one final check to ensure that:
 - the jack is completely vertical and stable.
 - there are no obstructions to the lift and that the handle can move freely up and down.
 - all personnel are in a safe position.
6. When satisfied, continue to pump the handle and lift the load to the height required.
7. NEVER allow anyone to get beneath the load until it is firmly supported on suitable, properly rated axle stands.

LOWERING THE VEHICLE



WARNING: ALWAYS LOWER IN A SLOW AND CONTROLLED MANNER, AND CHECK THAT THERE ARE NO OBSTACLES IN THE PATH OF THE LOAD'S DESCENT. BE EXTREMELY CAREFUL WHEN LOWERING HEAVY LOADS.

1. The lowering speed is controlled by the amount you turn the release valve. With the axle stands removed, check to ensure that there are no personnel

in the immediate vicinity before removing the handle from its housing, and engaging it with the release valve.

2. Very slowly turn the handle anticlockwise to open the release valve, and allow the jack to lower the load, under complete control. NEVER, under any circumstances, jerk the valve open.

MAINTENANCE

IMPORTANT: Only fully qualified personnel should attempt to repair the jack.

INSPECTION

1. Always visually inspect the jack before use, to ensure that all parts are correctly located and secure. Check for hydraulic leaks, signs of damage or worn parts. **Do not use the jack unless it is perfectly serviceable.**
 - A slight dampness on the ram is normal, but where leakage is found, the ram seals must be renewed by your Clarke Spares Department.
2. The jack should be fully inspected annually as follows:
 - Check for cracks and deformation of components.
 - Check operation and top up the oil level. (see below).
 - Remove completely, any rust or corrosion and repaint to prevent further corrosion.
 - Ensure that all decals and warning notices are in place and legible.
3. After use, store the jack with the ram in its lowest position. This not only relieves the hydraulic ram, but also prevents any possibility of corrosion to the ram.
4. Do not leave the jack in the open, exposed to the weather. Keep under cover. If stored for long periods, inspect before use, clean, and re-oil. For servicing, contact your CLARKE dealer or CLARKE Service dept.

TOPPING UP THE OIL

It may be necessary from time to time to top up the hydraulic oil level. Proceed as follows.

1. Turn the release valve counterclockwise and allow the ram to retract to its lowest position.
 - It may be necessary to apply force to the saddle for lowering without any weight on the jack.
2. With the jack in the level position, remove the filler plug and stand upright.
 - The oil should be level with the bottom of the oil filler hole.

3. If below this, top up.
4. Do not overfill. Only use the correct type of oil such as Clarke hydraulic oil (part number 3050830).
5. Replace the filler plug.
6. Check the jack for correct operation and purge any air from the system as described below.

PURGING AIR FROM THE JACK

1. Turn the release valve counterclockwise one full turn to open.
2. Pump the handle eight full strokes.
3. Turn the release valve clockwise to close the valve.
4. Pump the handle until the ram reaches maximum height and continue to pump several times to remove trapped air.
5. Turn the release valve counterclockwise one full turn and lower the ram to its lowest position. Apply pressure if necessary.
6. Turn the release valve clockwise to the closed position and check for correct operation. It may be necessary to perform the procedure more than once to evacuate all the air.

TROUBLESHOOTING

Problem	Check	Solution
Jack will not lift to full height	Low oil level	Check oil level
Jack will not hold load	Release valve not closing Hydraulic oil contaminated Pump valves not sealing Cylinder ram binding	Contact Clarke Service Department
Jack piston will not lower	Cylinder ram binding Parts worn Internal damage Broken or disconnected return spring Lift arm linkage bent or binding	Contact Clarke Service Department
Jack feels spongy when lifting	See Air Purging section	See air purging procedure above

PARTS DIAGRAMS

CTBJ5

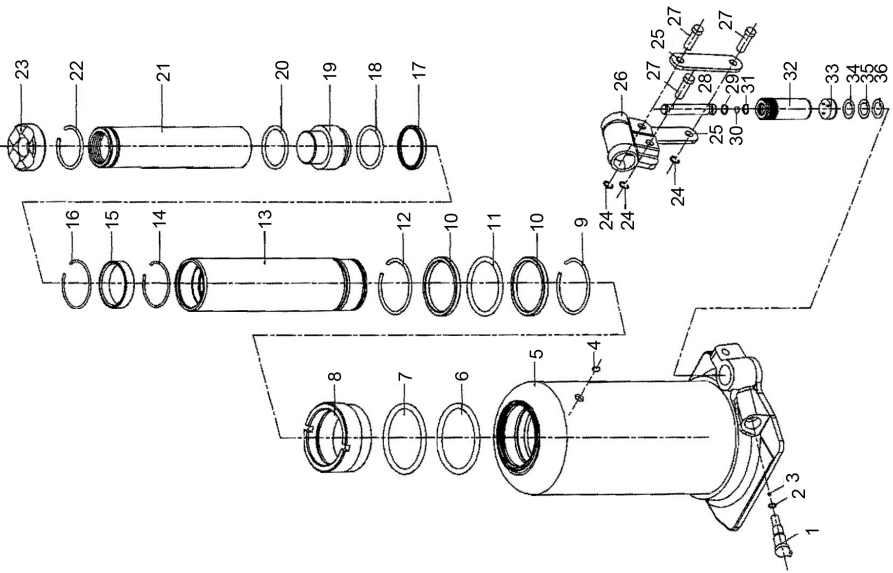

CTBJ10 & CTBJ12

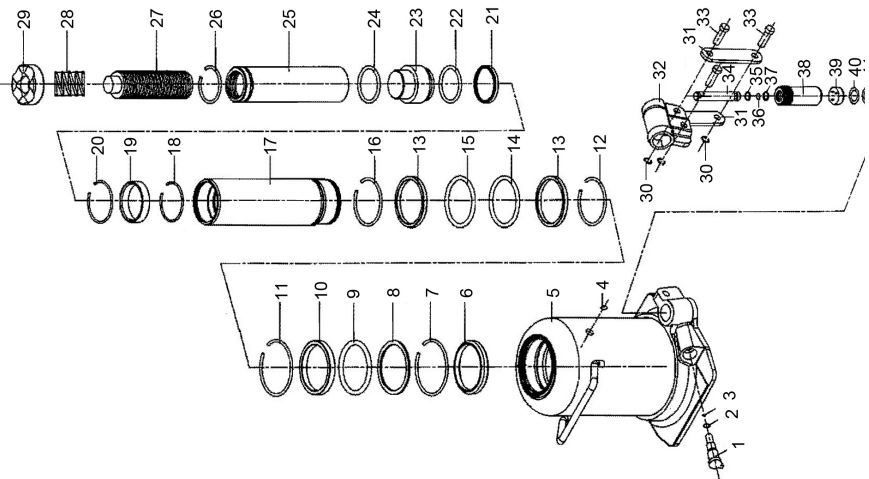

CTBJ5, CTBJ10 & CTBJ12 PARTS LIST

No	CTBJ5	CTBJ10/12
1	Release valve	Release valve
2	O-ring	O-ring
3	Steel Ball	Steel Ball
4	Filler Plug	Filler Plug
5	Base Casting	Base Casting
6	O-ring	Sealing Ring
7	O-ring	Circlip
8	Breech Block	O-ring
9	Circlip	O-ring
10	Piston Ring	Sealing Ring
11	Piston Ring	Circlip
12	Circlip	Circlip
13	Outer Piston	Sealing Ring
14	Circlip	O-ring
15	Nylon Ring	O-ring
16	Block Ring	Circlip
17	Piston Ring	Lower Piston
18	Nylon Ring	Circlip
19	Piston Head	Sealing Ring
20	Gasket	Circlip
21	Inner Piston	Sealing Ring

No	CTBJ5	CTBJ10/12
22	Circlip	O-ring
23	Cap Nut	Piston Head
24	Circlip	O-ring
25	Link Plate	Upper Piston
26	Handle Bracket	Circlip
27	Hinge Pin	Screwed Rod
28	Pump Piston	Spring
29	Dustproof Ring	Cap Nut
30	Circlip	Circlip
31	O-ring	Link Plate
32	Housing	Handle Bracket
33	Valve End	Hinge Pin
34	Gasket	Pump Piston
35	Nylon Ring	Dustproof Ring
36	Nylon Ring	Circlip
37		O-ring
38		Valve Housing
39		Valve End
40		Gasket
41		Nylon Ring
42		Nylon Ring

DECLARATION OF CONFORMITY



Clarke[®]
INTERNATIONAL

Hemnall Street, Epping, Essex CM16 4LG

DECLARATION OF CONFORMITY

This is an important document and should be retained.

We hereby declare that this product(s) complies with the following directive(s):

2006/42/EC Machinery Directive.

The following standards have been applied to the product(s):

BS EN 1494:2000+A1:2008

The technical documentation required to demonstrate that the product(s) meet(s) the requirement(s) of the aforementioned directive(s) has been compiled and is available for inspection by the relevant enforcement authorities.

The CE mark was first applied in: 2014

Product Description:	Telescopic Bottle Jack(s)
Model number(s):	CTBJ5, CTBJ10, CTBJ12
Serial / batch Number:	N/A
Date of Issue:	09/12/2014

Signed:

J.A. Clarke
Director

A SELECTION FROM THE VAST RANGE OF

Clarke®

QUALITY PRODUCTS

AIR COMPRESSORS

From DIY to industrial, Plus air tools, spray guns and accessories.

GENERATORS

Prime duty or emergency standby for business, home and leisure.

POWER WASHERS

Hot and cold, electric and engine driven - we have what you need

WELDERS

Mig, Arc, Tig and Spot. From DIY to auto/industrial.

METALWORKING

Drills, grinders and saws for DIY and professional use.

WOODWORKING

Saws, sanders, lathes, mortisers and dust extraction.

HYDRAULICS

Cranes, body repair kits, transmission jacks for all types of workshop use.

WATER PUMPS

Submersible, electric and engine driven for DIY, agriculture and industry.

POWER TOOLS

Angle grinders, cordless drill sets, saws and sanders.

STARTERS/CHARGERS

All sizes for car and commercial use.



PARTS & SERVICE: 0208 988 7400

E-mail: Parts@clarkeinternational.com or Service@clarkeinternational.com

SALES: UK 01992 565333 or Export 00 44 (0)1992 565335

Clarke® INTERNATIONAL Hemnall Street, Epping, Essex CM16 4LG
www.clarkeinternational.com